

# Standalone 750mA Li-Ion Battery Charger in 2 × 2 DFN with NTC Thermistor Input

## FEATURES

- Complete Linear Charger in 2mm × 2mm DFN Package
- C/10 Charge Current Detection Output
- Timer Charge Termination
- Charge Current Programmable Up to 750mA with 5% Accuracy
- No External MOSFET, Sense Resistor or Blocking Diode Required
- NTC Thermistor Input for Temperature Qualified Charging
- Preset 4.2V Float Voltage with 0.6% Accuracy
- Constant-Current/Constant-Voltage Operation with Thermal Feedback to Maximize Charge Rate Without Risk of Overheating
- Charge Current Monitor Output for Gas Gauging
- Automatic Recharge
- Charges Single-Cell Li-Ion Batteries Directly from USB Port
- 20µA Supply Current in Shutdown Mode
- Soft-Start Limits Inrush Current
- Tiny 6-Lead (2mm × 2mm) DFN Package

## APPLICATIONS

- Wireless PDAs
- Cellular Phones
- Portable Electronics

LT, LT, LTC, LTM, Linear Technology and the Linear logo are registered trademarks of Linear Technology Corporation. All other trademarks are the property of their respective owners. Protected by U.S. Patents, including 6522118, 6700364.

## DESCRIPTION

The **LTC<sup>®</sup>4069** is a complete constant-current/constant-voltage linear charger for single-cell lithium-ion batteries. The 2mm × 2mm DFN package and low external component count make the LTC4069 especially well-suited for portable applications. Furthermore, LTC4069 is specifically designed to work within USB power specifications.

The  $\overline{\text{CHRG}}$  pin indicates when charge current has dropped to ten percent of its programmed value (C/10). An internal timer terminates charging according to battery manufacturer specifications.

No external sense resistor or blocking diode is required due to the internal MOSFET architecture. Thermal feedback regulates charge current to limit the die temperature during high power operation or high ambient temperature conditions.

When the input supply (wall adapter or USB supply) is removed, the LTC4069 automatically enters a low current state, dropping battery drain current to less than 1µA. With power applied, LTC4069 can be put into shutdown mode, reducing the supply current to less than 20µA.

The LTC4069 also includes automatic recharge, low-battery charge conditioning (trickle charging), soft-start (to limit inrush current) and an NTC thermistor input used to monitor battery temperature.

The LTC4069 is available in a tiny 6-lead, low profile (0.75mm) 2mm × 2mm DFN package.

## TYPICAL APPLICATION

Standalone Li-Ion Battery Charger

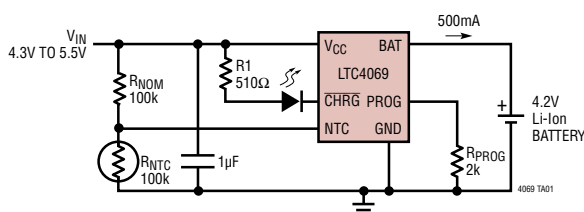

Complete Charge Cycle (1100mAh Battery)

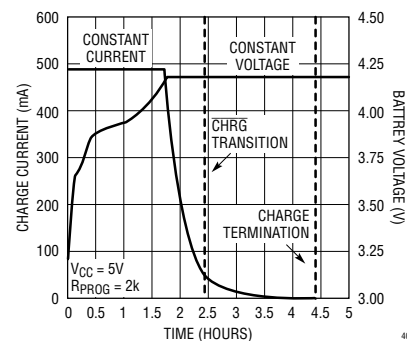

## ABSOLUTE MAXIMUM RATINGS

(Note 1)

$V_{CC}$	$t < 1\text{ms}$ and Duty Cycle $< 1\%$ .....	-0.3V to 7V
	Steady State .....	-0.3V to 6V
BAT, CHRG	.....	-0.3V to 6V
PROG, NTC	.....	-0.3V to $V_{CC} + 0.3\text{V}$
BAT Short-Circuit Duration.....		Continuous
BAT Pin Current .....		800mA
PROG Pin Current .....		800 $\mu\text{A}$
Junction Temperature (Note 6) .....		125°C
Operating Temperature Range (Note 2)....		-40°C to 85°C
Storage Temperature Range.....		-65°C to 125°C

## PIN CONFIGURATION

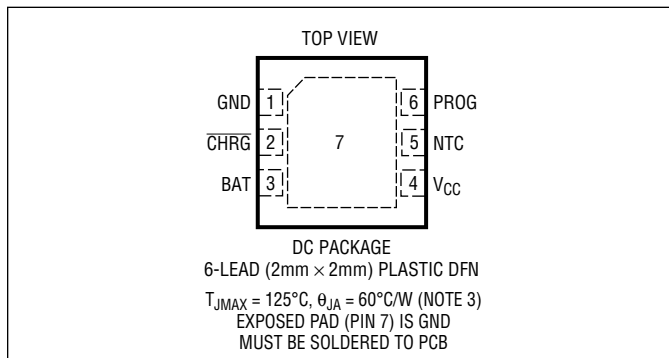

## ORDER INFORMATION

LEAD FREE FINISH	TAPE AND REEL	PART MARKING	PACKAGE DESCRIPTION	TEMPERATURE RANGE
LTC4069EDC#PBF	LTC4069EDC#TRPBF	LBZX	6-Lead (2mm x 2mm) Plastic DFN	-40°C to 85°C

Consult LTC Marketing for parts specified with wider operating temperature ranges.

Consult LTC Marketing for information on non-standard lead based finish parts.

For more information on lead free part marking, go to: <http://www.linear.com/leadfree/>

For more information on tape and reel specifications, go to: <http://www.linear.com/tapeandree/>

## ELECTRICAL CHARACTERISTICS

The ● denotes specifications which apply over the full operating temperature range, otherwise specifications are  $T_A = 25^{\circ}\text{C}$ .

$V_{CC} = 5\text{V}$ ,  $V_{BAT} = 3.8\text{V}$ ,  $V_{NTC} = 0\text{V}$  unless otherwise specified. (Note 2)

SYMBOL	PARAMETER	CONDITIONS	MIN	TYP	MAX	UNITS	
$V_{CC}$	$V_{CC}$ Supply Voltage	(Note 4)	● 3.75		5.5	V	
$I_{CC}$	Quiescent $V_{CC}$ Supply Current	$V_{BAT} = 4.5\text{V}$ (Forces $I_{BAT}$ and $I_{PROG} = 0$ )	●	120	250	$\mu\text{A}$	
$I_{CCMS}$	$V_{CC}$ Supply Current in Shutdown	Float PROG	●	20	40	$\mu\text{A}$	
$I_{CCUV}$	$V_{CC}$ Supply Current in Undervoltage Lockout	$V_{CC} < V_{BAT}$ , $V_{CC} = 3.5\text{V}$ , $V_{BAT} = 4\text{V}$	●	6	11	$\mu\text{A}$	
$V_{FLOAT}$	$V_{BAT}$ Regulated Output Voltage	$I_{BAT} = 2\text{mA}$ $I_{BAT} = 2\text{mA}$ , $0^{\circ}\text{C} < T_A < 85^{\circ}\text{C}$		4.175 4.158	4.2 4.242	V V	
$I_{BAT}$	BAT Pin Current	$R_{PROG} = 10\text{k}$ (0.1%), Current Mode $R_{PROG} = 2\text{k}$ (0.1%), Current Mode	● ●	88 475	100 500	112 525	mA mA
$I_{BMS}$	Battery Drain Current in Shutdown Mode	Floating PROG, $V_{CC} > V_{BAT}$	●	-1	0	1	$\mu\text{A}$
$I_{BUV}$	Battery Drain Current in Undervoltage Lockout	$V_{CC} = 3.5\text{V}$ , $V_{BAT} = 4\text{V}$	●	0	1	4	$\mu\text{A}$
$V_{UVLO}$	$V_{CC}$ Undervoltage Lockout Voltage	$V_{CC}$ Rising $V_{CC}$ Falling	● ●	3.4 2.8	3.6 3	3.8 3.2	V V
$V_{PROG}$	PROG Pin Voltage	$R_{PROG} = 2\text{k}$ , $I_{PROG} = 500\mu\text{A}$ $R_{PROG} = 10\text{k}$ , $I_{PROG} = 100\mu\text{A}$	● ●	0.98 0.98	1 1	1.02 1.02	V V
$V_{ASD}$	Automatic Shutdown Threshold Voltage	$(V_{CC} - V_{BAT})$ , $V_{CC}$ Low to High $(V_{CC} - V_{BAT})$ , $V_{CC}$ High to Low		60 15	80 30	100 45	mV mV

4069fc

## ELECTRICAL CHARACTERISTICS

The ● denotes specifications which apply over the full operating temperature range, otherwise specifications are  $T_A = 25^\circ\text{C}$ .  
 $V_{CC} = 5\text{V}$ ,  $V_{BAT} = 3.8\text{V}$ ,  $V_{NTC} = 0\text{V}$  unless otherwise specified. (Note 2)

SYMBOL	PARAMETER	CONDITIONS	MIN	TYP	MAX	UNITS	
$I_{PROG}$	PROG Pin Pull-Up Current	$V_{PROG} > 1\text{V}$		3		$\mu\text{A}$	
$V_{MS, PROG}$	PROG Shutdown Threshold Voltage	$V_{PROG}$ Rising	● 3.7	4	4.3	V	
$t_{SS}$	Soft-Start Time			170		$\mu\text{s}$	
$I_{TRKL}$	Trickle Charge Current	$V_{BAT} = 2\text{V}$ , $R_{PROG} = 2\text{k}$ (0.1%)		35	50	65	$\text{mA}$
$V_{TRKL}$	Trickle Charge Threshold Voltage	$V_{BAT}$ Rising	● 2.7	2.9	3.05	V	
$V_{TRHYS}$	Trickle Charge Hysteresis Voltage			90		$\text{mV}$	
$\Delta V_{RECHRG}$	Recharge Battery Threshold Voltage	$V_{FLOAT} - V_{RECHRG}$ , $0^\circ\text{C} < T_A < 85^\circ\text{C}$		70	100	130	$\text{mV}$
$\Delta V_{UVCL1}$	$(V_{CC} - V_{BAT})$ Undervoltage Current Limit	$I_{BAT} = 90\%$ Programmed Charge Current		180	220	330	$\text{mV}$
$\Delta V_{UVCL2}$		$I_{BAT} = 10\%$ Programmed Charge Current		90	125	150	$\text{mV}$
$t_{TIMER}$	Termination Timer		● 3	4.5	6	Hrs	
	Recharge Timer		● 1.5	2.25	3	Hrs	
	Low-Battery Trickle Charge Time	$V_{BAT} = 2.5\text{V}$	● 0.75	1.125	1.5	Hrs	
$V_{CHRG}$	$\overline{\text{CHRG}}$ Pin Output Low Voltage	$I_{CHRG} = 5\text{mA}$	●	60	105	$\text{mV}$	
$I_{CHRG}$	$\overline{\text{CHRG}}$ Pin Leakage Current	$V_{BAT} = 4.5\text{V}$ , $V_{CHRG} = 5\text{V}$	●	0	1	$\mu\text{A}$	
$I_{C/10}$	End of Charge Indication Current Level	$R_{PROG} = 2\text{k}$ (Note 5)	● 0.08	0.095	0.11	$\text{mA}/\text{mA}$	
$T_{LIM}$	Junction Temperature in Constant Temperature Mode			115		$^\circ\text{C}$	
$R_{ON}$	Power FET "On" Resistance (Between $V_{CC}$ and BAT)	$I_{BAT} = 350\text{mA}$		450		$\text{m}\Omega$	
$f_{BADBAT}$	Defective Battery Detection $\overline{\text{CHRG}}$ Pulse Frequency			2		Hz	
$D_{BADBAT}$	Defective Battery Detection $\overline{\text{CHRG}}$ Pulse Frequency Duty Ratio			75		%	
$I_{NTC}$	NTC Pin Current	$V_{NTC} = 2.5\text{V}$			1	$\mu\text{A}$	
$V_{COLD}$	Cold Temperature Fault Threshold Voltage	Rising Voltage Threshold Hysteresis		$0.76 \cdot V_{CC}$		V	
					$0.015 \cdot V_{CC}$		V
$V_{HOT}$	Hot Temperature Fault Threshold Voltage	Falling Voltage Threshold Hysteresis		$0.35 \cdot V_{CC}$		V	
					$0.017 \cdot V_{CC}$		V
$V_{NTC-DIS}$	NTC Disable Threshold Voltage	Falling Threshold; $V_{CC} = 5\text{V}$		82		$\text{mV}$	
$V_{DIS-HYS}$	NTC Disable Hysteresis Voltage			50		$\text{mV}$	
$f_{NTC}$	Fault Temperature $\overline{\text{CHRG}}$ Pulse Frequency			2		Hz	
$D_{NTC}$	Fault Temperature $\overline{\text{CHRG}}$ Pulse Frequency Duty Ratio			25		%	

**Note 1:** Stresses beyond those listed under Absolute Maximum Ratings may cause permanent damage to the device. Exposure to any Absolute Maximum Rating condition for extended periods may affect device reliability and lifetime.

**Note 2:** The LTC4069 is guaranteed to meet performance specifications from  $0^\circ\text{C}$  to  $85^\circ\text{C}$ . Specifications over the  $-40^\circ\text{C}$  to  $85^\circ\text{C}$  operating temperature range are assured by design, characterization and correlation with statistical process controls.

**Note 3:** Failure to solder the exposed backside of the package to the PCB board ground plane will result in a thermal resistance much higher than rated.

**Note 4:** Although the LTC4069 functions properly at  $3.75\text{V}$ , full charge current requires an input voltage greater than the desired final battery voltage per the  $\Delta V_{UVCL1}$  specification.

**Note 5:**  $I_{C/10}$  is expressed as a fraction of measured full charge current with indicated PROG resistor.

**Note 6:** This IC includes overtemperature protection that is intended to protect the device during momentary overload conditions. Junction temperature will exceed  $125^\circ\text{C}$  when overtemperature protection is active. Continuous operation above the specified maximum operating junction temperature may impair device reliability.

# TYPICAL PERFORMANCE CHARACTERISTICS

**Battery Regulation (Float) Voltage vs Battery Charge Current**

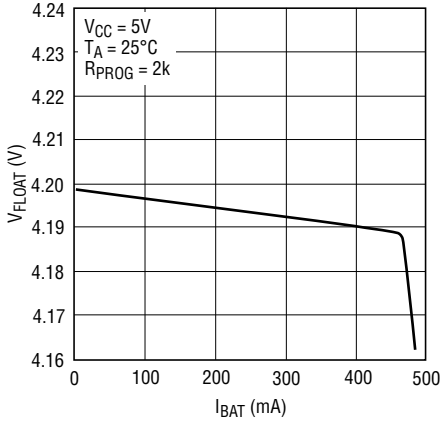

4069 G01

**Battery Regulation (Float) Voltage vs Temperature**

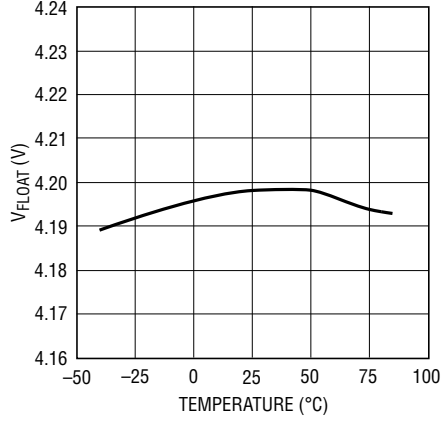

4069 G02

**Battery Regulation (Float) Voltage vs Supply Voltage**

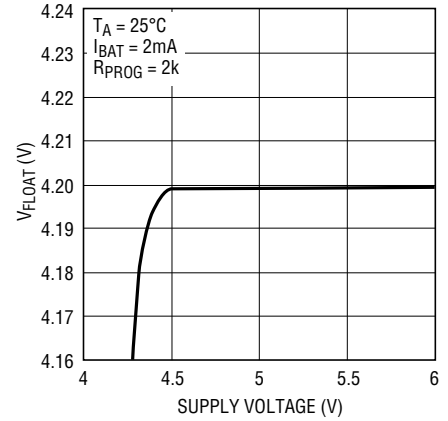

4069 G03

**Charge Current vs Supply Voltage (Constant-Current Mode)**

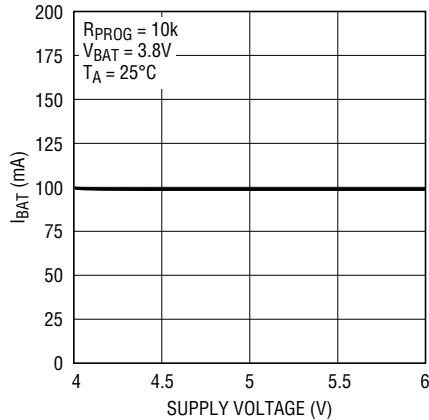

4069 G04

**Charge Current vs Battery Voltage**

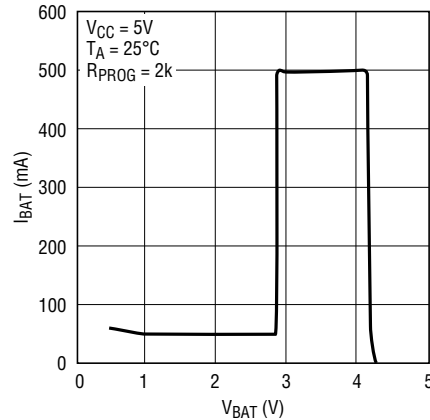

4069 G05

**Charge Current vs Ambient Temperature with Thermal Regulation (Constant-Current Mode)**

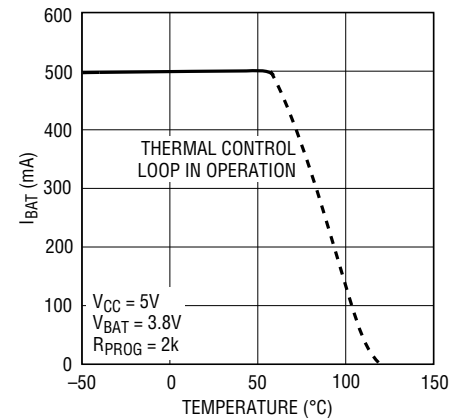

4069 G06

**PROG Pin Voltage vs Temperature (Constant-Current Mode)**

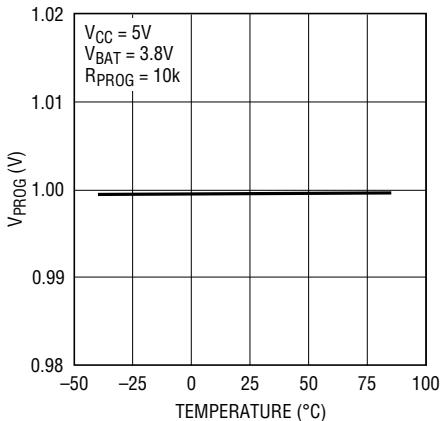

4069 G07

**PROG Pin Voltage vs Charge Current**

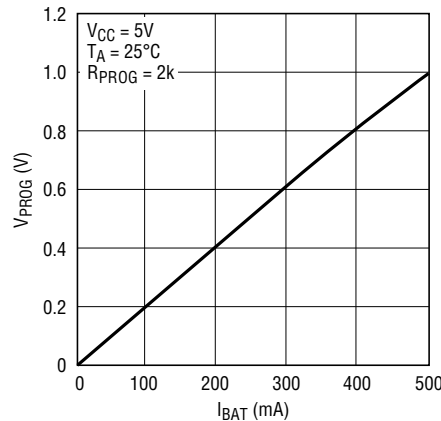

4069 G08

**Power FET On-Resistance vs Temperature**

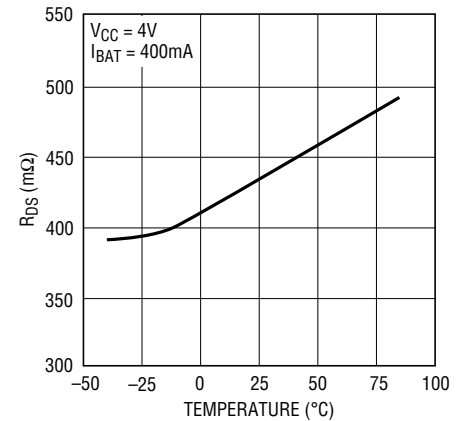

4069 G09

# TYPICAL PERFORMANCE CHARACTERISTICS

**Undervoltage Lockout Threshold Voltage vs Temperature**

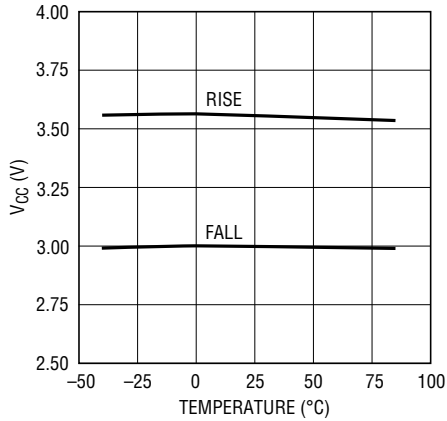

4069 G16

**Trickle Charge Current vs Supply Voltage**

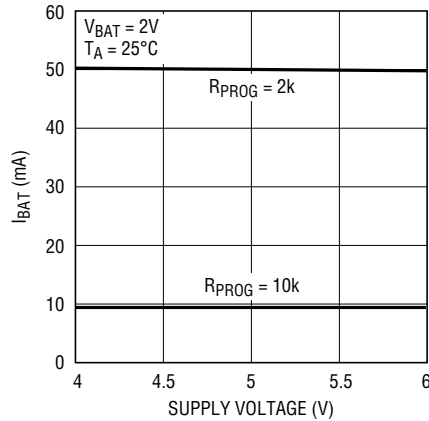

4069 G14

**Trickle Charge Current vs Temperature**

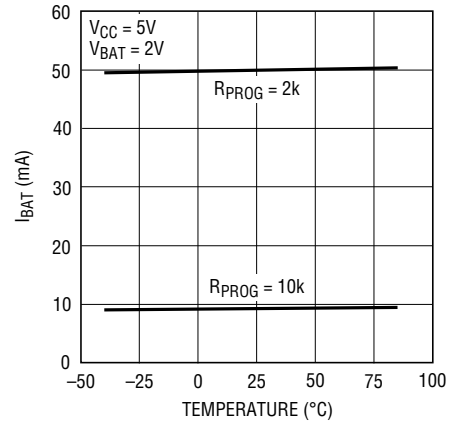

4069 G15

**CHRG Pin Output Low Voltage vs Temperature**

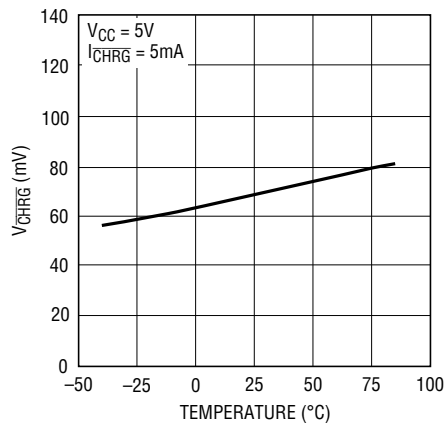

4069 G10

**Timer Accuracy vs Temperature**

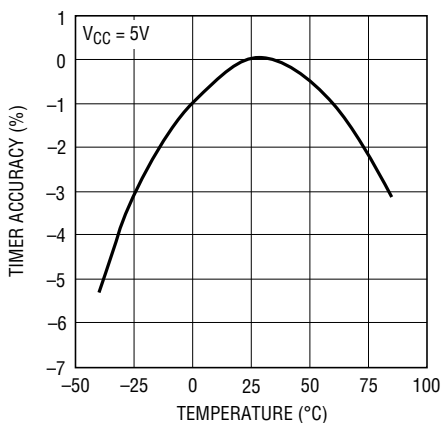

4069 G18

**Timer Accuracy vs Supply Voltage**

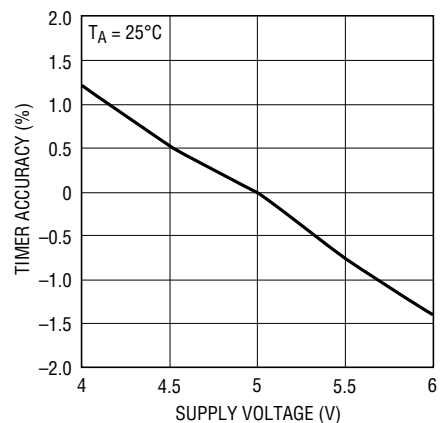

4069 G19

**PROG Pin Shutdown Voltage Threshold vs Temperature**

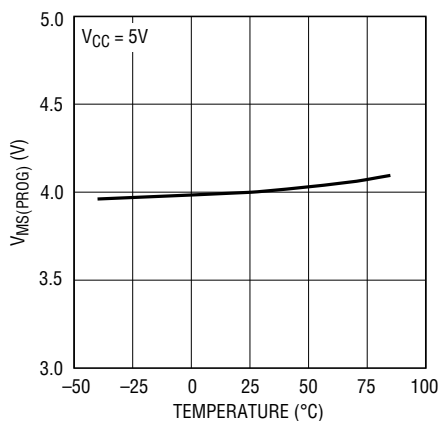

4069 G20

**PROG Pin Shutdown Voltage vs Supply Voltage**

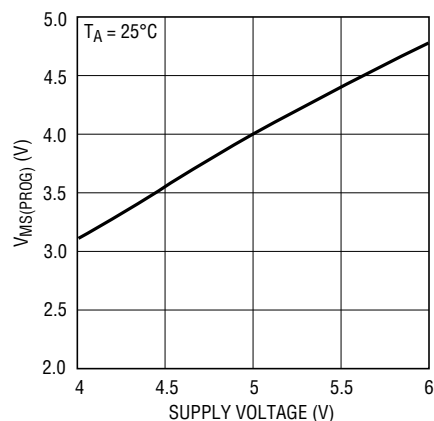

4069 G21

## PIN FUNCTIONS

**GND (Pin 1):** Ground.

**$\overline{\text{CHRG}}$  (Pin 2):** Open-Drain Charge Status Output. The charge status indicator pin has three states: pull-down, pulse at 2Hz and high impedance state. This output can be used as a logic interface or as an LED driver. When the battery is being charged, the  $\overline{\text{CHRG}}$  pin is pulled low by an internal N-channel MOSFET. When the charge current drops to 10% of full-scale current, the  $\overline{\text{CHRG}}$  pin is forced to a high impedance state. If the battery voltage remains below 2.9V for one quarter of the charge time, the battery is considered defective and the  $\overline{\text{CHRG}}$  pin pulses at a frequency of 2Hz (75% duty cycle). When the NTC pin voltage rises above  $0.76 \cdot V_{\text{CC}}$  or drops below  $0.35 \cdot V_{\text{CC}}$ , the  $\overline{\text{CHRG}}$  pin pulses at a frequency of 2Hz (25% duty cycle).

**BAT (Pin 3):** Charge Current Output. Provides charge current to the battery and regulates the final float voltage to 4.2V. An internal precision resistor divider on this pin sets the float voltage and is disconnected in shutdown mode.

**VCC (Pin 4):** Positive Input Supply Voltage. This pin provides power to the charger.  $V_{\text{CC}}$  can range from 3.75V to 5.5V. This pin should be bypassed with at least a 1 $\mu$ F capacitor. When  $V_{\text{CC}}$  is within 32mV of the BAT pin voltage, the LTC4069 enters shutdown mode, dropping  $I_{\text{BAT}}$  to about 1 $\mu$ A.

**NTC (Pin 5):** Input to the NTC (Negative Temperature Coefficient) Thermistor Temperature Monitoring Circuit. Under normal operation, connect a thermistor from the NTC pin to ground and a resistor of equal value from the NTC pin to  $V_{\text{CC}}$ . When the voltage at this pin drops below  $0.35 \cdot V_{\text{CC}}$  at hot temperatures or rises above  $0.76 \cdot V_{\text{CC}}$  at cold, charging is suspended, the internal timer is frozen and the  $\overline{\text{CHRG}}$  pin output will start to pulse at 2Hz. Pulling this pin below  $0.016 \cdot V_{\text{CC}}$  disables the NTC feature. There is approximately 3°C of temperature hysteresis associated with each of the input comparator's thresholds.

**PROG (Pin 6):** Charge Current Program and Charge Current Monitor Pin. Connecting a 1% resistor,  $R_{\text{PROG}}$ , to ground programs the charge current. When charging in constant-current mode, this pin servos to 1V. In all modes, the voltage on this pin can be used to measure the charge current using the following formula:

$$I_{\text{BAT}} = \frac{V_{\text{PROG}}}{R_{\text{PROG}}} \cdot 1000$$

Floating the PROG pin puts the charger in shutdown mode. In shutdown mode, the LTC4069 has less than 20 $\mu$ A supply current and about 1 $\mu$ A battery drain current.

**Exposed Pad (Pin 7):** Ground. The Exposed Pad must be soldered to the PCB ground to provide both electrical contact and rated thermal performance.

## SIMPLIFIED BLOCK DIAGRAM

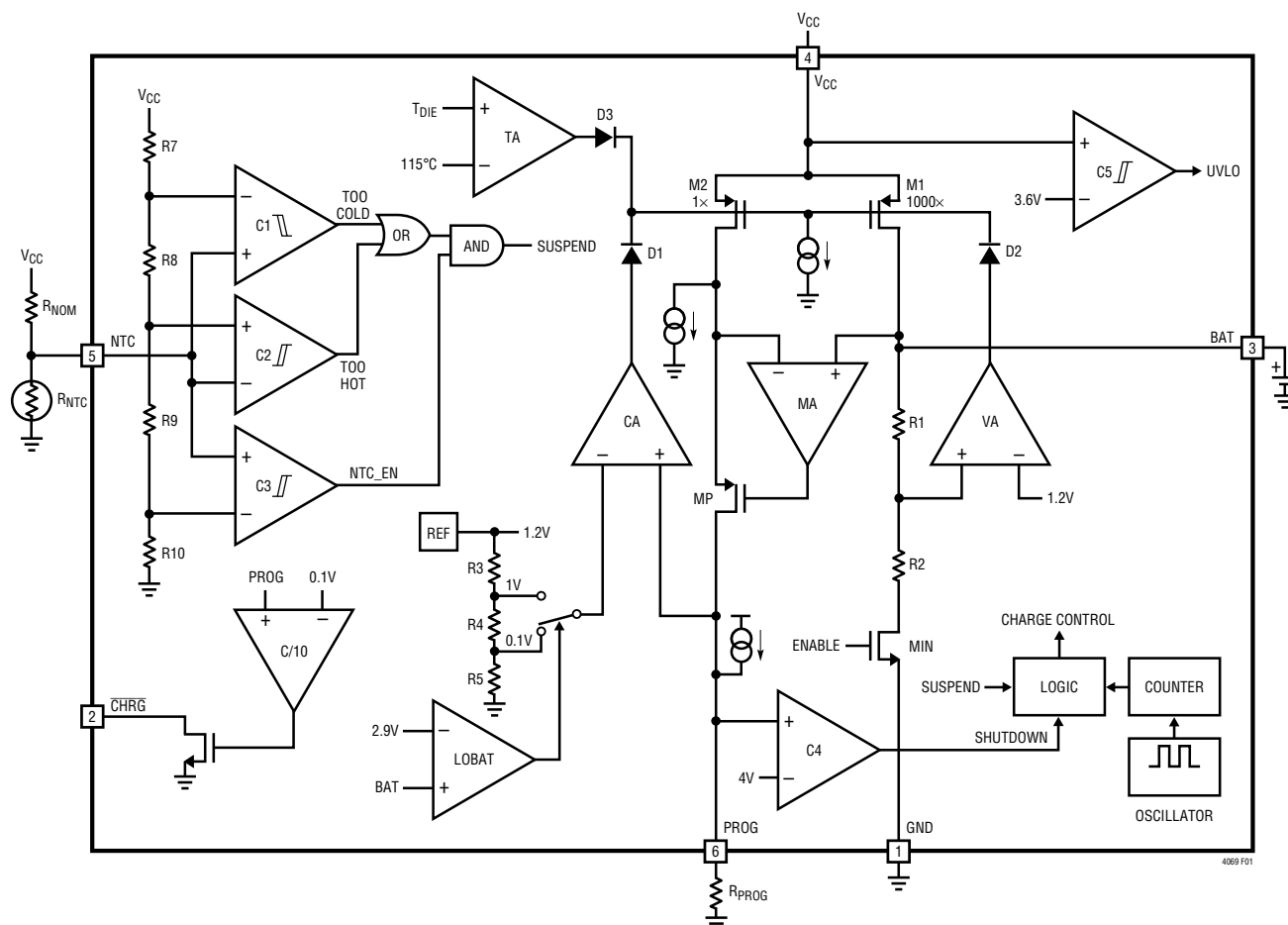

Figure 1. LTC4069 Block Diagram

## OPERATION

The LTC4069 is a linear battery charger designed primarily for charging single-cell lithium-ion batteries. Featuring an internal P-channel power MOSFET, the charger uses a constant-current/constant-voltage charge algorithm with programmable current. Charge current can be programmed up to 750mA with a final float voltage accuracy of  $\pm 0.6\%$ . The CHRG open-drain status output indicates if C/10 has been reached. No blocking diode or external sense resistor is required; thus, the basic charger circuit requires only two external components. An internal termination timer and trickle charge low-battery conditioning adhere to battery manufacturer safety guidelines. Furthermore, the LTC4069 is capable of operating from a USB power source.

An internal thermal limit reduces the programmed charge current if the die temperature attempts to rise above a preset value of approximately 115°C. This feature protects the LTC4069 from excessive temperature and allows the user to push the limits of the power handling capability of a given circuit board without risk of damaging the LTC4069 or external components. Another benefit of the LTC4069 thermal limit is that charge current can be set according to typical, not worst-case, ambient temperatures for a given application with the assurance that the charger will automatically reduce the current in worst-case conditions.

## OPERATION

The charge cycle begins when the voltage at the  $V_{CC}$  pin rises above 3.5V and approximately 80mV above the BAT pin voltage, a 1% program resistor is connected from the PROG pin to ground and the NTC pin voltage stays between  $0.76 \cdot V_{CC}$  and  $0.35 \cdot V_{CC}$  or below  $0.016 \cdot V_{CC}$ .

If the BAT pin voltage is below 2.9V, the charger goes into trickle charge mode, charging the battery at one-tenth the programmed charge current to bring the cell voltage up to a safe level for charging. If the BAT pin voltage is above 4.1V, the charger will not charge the battery as the cell is near full capacity. Otherwise, the charger goes into the fast charge constant-current mode.

When the BAT pin approaches the final float voltage (4.2V), the LTC4069 enters constant-voltage mode and the charge current begins to decrease. When the current drops to 10% of the full-scale charge current, an internal comparator turns off the N-channel MOSFET on the  $\overline{CHRG}$  pin and the pin assumes a high impedance state.

An internal timer sets the total charge time,  $t_{TIMER}$  (typically 4.5 hours). When this time elapses, the charge cycle terminates and the  $\overline{CHRG}$  pin assumes a high impedance state. The charge cycle will automatically restart if the BAT pin voltage falls below  $V_{RECHRG}$  (typically 4.1V). To manually restart the charge cycle, remove the input voltage and reapply it, or momentarily float the PROG pin and reconnect it.

### Programming Charge Current

The charge current is programmed using a single resistor from the PROG pin to ground. The battery charge current is 1000 times the current out of the PROG pin. The program resistor and the charge current are calculated using the following equations:

$$R_{PROG} = 1000 \cdot \frac{1V}{I_{CHG}}, I_{CHG} = \frac{1000V}{R_{PROG}}$$

The charge current out of the BAT pin can be determined at any time by monitoring the PROG pin voltage and using the following equation:

$$I_{BAT} = \frac{V_{PROG}}{R_{PROG}} \cdot 1000$$

### Undervoltage Lockout (UVLO)

An internal undervoltage lockout circuit monitors the input voltage and keeps the charger in undervoltage lockout until  $V_{CC}$  rises above 3.6V and approximately 80mV above the BAT pin voltage. The 3.6V UVLO circuit has a built-in hysteresis of approximately 0.6V and the automatic shutdown threshold has a built-in hysteresis of approximately 50mV. During undervoltage lockout conditions, maximum battery drain current is 4 $\mu$ A and maximum supply current is 11 $\mu$ A.

### Shutdown Mode

The LTC4069 can be disabled by floating the PROG pin. In shutdown mode, the battery drain current is reduced to less than 1 $\mu$ A and the supply current to about 20 $\mu$ A.

### Timer and Recharge

The LTC4069 has an internal termination timer that starts when an input voltage greater than the undervoltage lockout threshold is applied to  $V_{CC}$ , or when leaving shutdown and the battery voltage is less than the recharge threshold.

At power-up or when exiting shutdown, if the battery voltage is less than the recharge threshold, the charge time is set to 4.5 hours. If the battery temperature is either too high or too low, the timer will pause until the battery returns to normal temperature. If the battery is greater than the recharge threshold at power-up or when exiting shutdown, the timer will not start and charging is prevented since the battery is at or near full capacity.

Once the charge cycle terminates, the LTC4069 continuously monitors the BAT pin voltage using a comparator with a 2ms filter time. When the battery voltage falls

## OPERATION

below 4.1V (which corresponds to 80% to 90% battery capacity), a new charge cycle is initiated and a 2.25 hour timer begins. This ensures that the battery is kept at, or near, a fully charged condition and eliminates the need for periodic charge cycle initiations. Also, if the battery voltage does not exceed the recharge threshold voltage when the timer ends, the timer resets and a 2.25 hour recharge cycle begins. The  $\overline{\text{CHRG}}$  output assumes a strong pull-down state during recharge cycles until C/10 is reached when it transitions to a high impedance state.

### Trickle Charge and Defective Battery Detection

At the beginning of a charge cycle, if the battery voltage is low (below 2.9V), the charger goes into trickle charge, reducing the charge current to 10% of the full-scale current. If the low-battery voltage persists for one quarter of the total time (1.125 hour), the battery is assumed to be defective, the charge cycle is terminated and the  $\overline{\text{CHRG}}$  pin output pulses at a frequency of 2Hz with a 75% duty cycle. If for any reason the battery voltage rises above 2.9V, the charge cycle will be restarted. To restart the charge cycle (i.e., when the defective battery is replaced with a discharged battery), simply remove the input voltage and reapply it or momentarily float the PROG pin and reconnect it.

### $\overline{\text{CHRG}}$ Status Output Pin

The charge status indicator pin has three states: pull-down, pulse at 2Hz (see Trickle Charge and Defective Battery Detection and Battery Temperature Monitoring) and high impedance. The pull-down state indicates that the LTC4069 is in a charge cycle. A high impedance state indicates that the charge current has dropped below 10% of the full-scale current or the LTC4069 is disabled. Figure 2 shows the  $\overline{\text{CHRG}}$  status under various conditions.

### Charge Current Soft-Start and Soft-Stop

The LTC4069 includes a soft-start circuit to minimize the inrush current at the start of a charge cycle. When a charge cycle is initiated, the charge current ramps from zero to the full-scale current over a period of approximately

170 $\mu$ s. Likewise, internal circuitry slowly ramps the charge current from full-scale to zero when the charger is shut off or self terminates. This has the effect of minimizing the transient current load on the power supply during start-up and charge termination.

### Constant-Current/Constant-Voltage/ Constant-Temperature

The LTC4069 uses a unique architecture to charge a battery in a constant-current, constant-voltage and constant-temperature fashion. Figure 1 shows a Simplified Block Diagram of the LTC4069. Three of the amplifier feedback loops shown control the constant-current (CA), constant-voltage (VA), and constant-temperature (TA) modes. A fourth amplifier feedback loop (MA) is used to increase the output impedance of the current source pair, M1 and M2 (note that M1 is the internal P-channel power MOSFET). It ensures that the drain current of M1 is exactly 1000 times greater than the drain current of M2.

Amplifiers CA and VA are used in separate feedback loops to force the charger into constant-current or constant-voltage mode, respectively. Diodes D1 and D2 provide priority to either the constant-current or constant-voltage loop, whichever is trying to reduce the charge current the most. The output of the other amplifier saturates low which effectively removes its loop from the system. When in constant-current mode, CA servos the voltage at the PROG pin to be precisely 1V. VA servos its inverting input to an internal reference voltage when in constant-voltage mode and the internal resistor divider, made up of R1 and R2, ensures that the battery voltage is maintained at 4.2V. The PROG pin voltage gives an indication of the charge current during constant-voltage mode as discussed in "Programming Charge Current".

Transconductance amplifier, TA, limits the die temperature to approximately 115°C when in constant-temperature mode. Diode D3 ensures that TA does not affect the charge current when the die temperature is below approximately 115°C. The PROG pin voltage continues to give an indication of the charge current.

## OPERATION

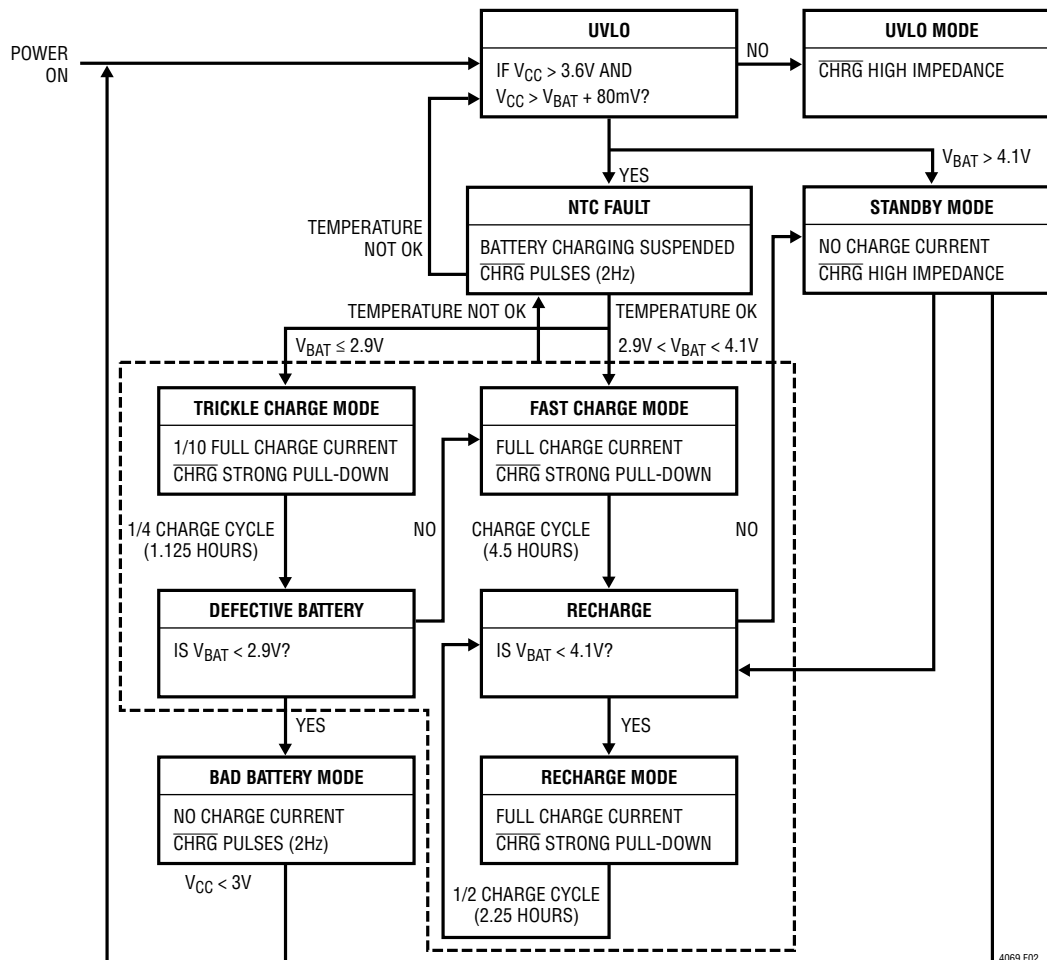

Figure 2. State Diagram of LTC4069 Operation

In typical operation, the charge cycle begins in constant-current mode with the current delivered to the battery equal to  $1000V/R_{PROG}$ . If the power dissipation of the LTC4069 results in the junction temperature approaching  $115^{\circ}C$ , the amplifier (TA) will begin decreasing the charge current to limit the die temperature to approximately  $115^{\circ}C$ . As the battery voltage rises, the LTC4069 either returns to constant-current mode or enters constant-voltage mode straight from constant-temperature mode.

Regardless of mode, the voltage at the PROG pin is proportional to the current delivered to the battery.

### Battery Temperature Monitoring via NTC

The battery temperature is measured by placing a negative temperature coefficient (NTC) thermistor close to the battery pack. The NTC circuitry is shown in Figure 3.

To use this feature, connect the NTC thermistor,  $R_{NTC}$ , between the NTC pin and ground and a resistor,  $R_{NOM}$ , from the NTC pin to  $V_{CC}$ .  $R_{NOM}$  should be a 1% resistor with a value equal to the value of the chosen NTC thermistor at  $25^{\circ}C$  (this value is 100k for a Vishay NTHS0603N01N1003J thermistor). The LTC4069 goes into hold mode when the

## OPERATION

value of the NTC thermistor drops to 0.53 times the value of  $R_{NOM}$ , which corresponds to approximately 40°C, and when the value of the NTC thermistor increases to 3.26 times the value of  $R_{NOM}$ , which corresponds to approximately 0°C. Hold mode freezes the timer and stops the charge cycle until the thermistor indicates a return to a valid temperature. For a Vishay NTHS0603N01N1003J thermistor, this value is 32.6k which corresponds to

approximately 0°C. The hot and cold comparators each have approximately 3°C of hysteresis to prevent oscillation about the trip point.

When the charger is in Hold mode (battery temperature is either too hot or too cold) the  $\overline{CHRG}$  pin pulses in a 2Hz, 25% duty cycle frequency unless the charge task is finished or the battery is assumed to be defective. If the NTC pin is grounded, the NTC function will be disabled.

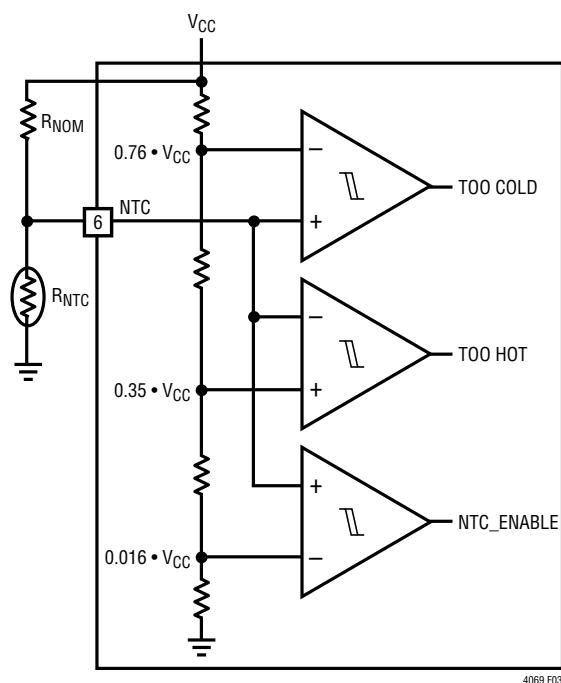

Figure 3. NTC Circuit Information

4069 F03

## APPLICATIONS INFORMATION

### Undervoltage Charge Current Limiting (UVCL)

The LTC4069 includes undervoltage charge ( $\Delta V_{UVCL1}$ ) current limiting that prevents full charge current until the input supply voltage exceeds approximately 220mV above the battery voltage. This feature is particularly useful if the LTC4069 is powered from a supply with long leads (or any relatively high output impedance).

For example, USB-powered systems tend to have highly variable source impedances (due primarily to cable quality and length). A transient load combined with such impedance can easily trip the UVLO threshold and turn the charger off unless undervoltage charge current limiting is implemented.

Consider a situation where the LTC4069 is operating under normal conditions and the input supply voltage begins to droop (e.g., an external load drags the input supply down). If the input voltage reaches  $V_{BAT} + \Delta V_{UVCL1}$  (approximately 220mV above the battery voltage), undervoltage charge current limiting will begin to reduce the charge current in an attempt to maintain  $\Delta V_{UVCL1}$  between the  $V_{CC}$  input and the BAT output of the IC. The LTC4069 will continue to operate at the reduced charge current until the input supply voltage is increased or constant-voltage mode reduces the charge current further.

### Operation from Current Limited Wall Adapter

By using a current limited wall adapter as the input supply, the LTC4069 dissipates significantly less power when programmed for a current higher than the limit of the supply as compared to using a non-current limited supply at the same charge current.

Consider a situation where an application demands a 600mA charge current for an 800mAh Li-Ion battery. If a typical 5V (non-current limited) input supply is used, the charger's peak power dissipation can exceed 1W.

Now consider the same scenario, but with a 5V input supply with a 600mA current limit. To take advantage of the current limited supply, it is necessary to program the LTC4069 to charge at a current above 600mA. Assume that the LTC4069 is programmed for 750mA (i.e.,  $R_{PROG} = 1.33k$ ) to ensure that part tolerances maintain a programmed current higher than 600mA. Since the LTC4069 will demand a charge current higher than the current limit of the voltage supply, the supply voltage will drop to the battery voltage plus 600mA times the "on" resistance of the internal PFET. The "on" resistance of the LTC4069 power device is approximately 450m $\Omega$  with a 5V supply. The actual "on" resistance will be slightly higher due to the fact that the input supply will drop to less than 5V. The power dissipated during this phase of charging is less than 240mW. That is a 76% improvement over the non-current limited supply power dissipation.

### USB and Wall Adapter Power

Although the LTC4069 allows charging from a USB port, a wall adapter can also be used to charge Li-Ion batteries. Figure 4 shows an example of how to combine wall adapter and USB power inputs. A P-channel MOSFET, MP1, is used to prevent back conducting into the USB port when a wall adapter is present and Schottky diode, D1, is used to prevent USB power loss through the 1k pull-down resistor.

Typically a wall adapter can supply significantly more current than the 500mA-limited USB port. Therefore, an N-channel MOSFET, MN1, and an extra program resistor are used to increase the charge current to 750mA when the wall adapter is present.

### Stability Considerations

The LTC4069 contains two control loops: constant-voltage and constant-current. The constant-voltage loop is stable without any compensation when a battery is connected

## APPLICATIONS INFORMATION

with low impedance leads. Excessive lead length, however, may add enough series inductance to require a bypass capacitor of at least  $1\mu\text{F}$  from BAT to GND. Furthermore, a  $4.7\mu\text{F}$  capacitor with a  $0.2\Omega$  to  $1\Omega$  series resistor from BAT to GND is required to keep ripple voltage low when the battery is disconnected.

High value capacitors with very low ESR (especially ceramic) may reduce the constant-voltage loop phase margin. Ceramic capacitors up to  $22\mu\text{F}$  may be used in parallel with a battery, but larger ceramics should be decoupled with  $0.2\Omega$  to  $1\Omega$  of series resistance.

In constant-current mode, the PROG pin is in the feedback loop, not the battery. Because of the additional pole created by the PROG pin capacitance, capacitance on this pin must be kept to a minimum. With no additional capacitance on the PROG pin, the charger is stable with program resistor values as high as  $25\text{k}$ . However, additional capacitance on this node reduces the maximum allowed program resistor. The pole frequency at the PROG pin should be kept above  $100\text{kHz}$ . Therefore, if the PROG pin is loaded with a capacitance,  $C_{\text{PROG}}$ , the following equation should be used to calculate the maximum resistance value for  $R_{\text{PROG}}$ :

$$R_{\text{PROG}} \leq \frac{1}{2\pi \cdot 10^5 \cdot C_{\text{PROG}}}$$

Average, rather than instantaneous, battery current may be of interest to the user. For example, if a switching power supply operating in low current mode is connected in parallel with the battery, the average current being pulled out of the BAT pin is typically of more interest than the instantaneous current pulses. In such a case, a simple RC filter can be used on the PROG pin to measure the average battery current as shown in Figure 5. A  $10\text{k}$  resistor has been added between the PROG pin and the filter capacitor to ensure stability.

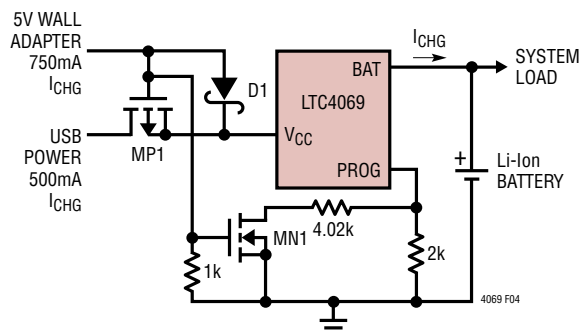

Figure 4. Combining Wall Adapter and USB Power

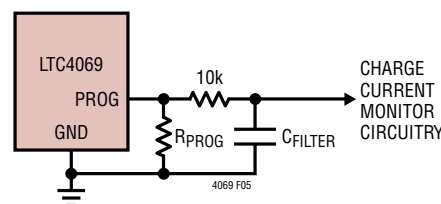

Figure 5. Isolating Capacitive Load on the PROG Pin and Filtering

### Power Dissipation

The conditions that cause the LTC4069 to reduce charge current through thermal feedback can be approximated by considering the power dissipated in the IC. For high charge currents, the LTC4069 power dissipation is approximately:

$$P_D = (V_{\text{CC}} - V_{\text{BAT}}) \cdot I_{\text{BAT}}$$

where  $P_D$  is the power dissipated,  $V_{\text{CC}}$  is the input supply voltage,  $V_{\text{BAT}}$  is the battery voltage and  $I_{\text{BAT}}$  is the charge current. It is not necessary to perform any worst-case power dissipation scenarios because the LTC4069 will automatically reduce the charge current to maintain the die temperature at approximately  $115^\circ\text{C}$ . However, the

## APPLICATIONS INFORMATION

approximate ambient temperature at which the thermal feedback begins to protect the IC is:

$$T_A = 115^\circ\text{C} - P_D \cdot \theta_{JA}$$

$$T_A = 115^\circ\text{C} - (V_{CC} - V_{BAT}) \cdot I_{BAT} \cdot \theta_{JA}$$

Example: Consider an LTC4069 operating from a 5V wall adapter providing 750mA to a 3.6V Li-Ion battery. The ambient temperature above which the LTC4069 will begin to reduce the 750mA charge current is approximately:

$$T_A = 115^\circ\text{C} - (5\text{V} - 3.6\text{V}) \cdot (750\text{mA}) \cdot 60^\circ\text{C}/\text{W}$$

$$T_A = 115^\circ\text{C} - (1.05\text{W} \cdot 60^\circ\text{C}/\text{W}) = 115^\circ\text{C} - 63^\circ\text{C}$$

$$T_A = 52^\circ\text{C}$$

The LTC4069 can be used above 70°C, but the charge current will be reduced from 750mA. The approximate current at a given ambient temperature can be calculated:

$$I_{BAT} = \frac{115^\circ\text{C} - T_A}{(V_{CC} - V_{BAT}) \cdot \theta_{JA}}$$

Using the previous example with an ambient temperature of 73°C, the charge current will be reduced to approximately:

$$I_{BAT} = \frac{115^\circ\text{C} - 73^\circ\text{C}}{(5\text{V} - 3.6\text{V}) \cdot 60^\circ\text{C}/\text{W}} = \frac{42^\circ\text{C}}{84^\circ\text{C}/\text{A}} = 500\text{mA}$$

Furthermore, the voltage at the PROG pin will change proportionally with the charge current as discussed in the Programming Charge Current section.

It is important to remember that LTC4069 applications do not need to be designed for worst-case thermal conditions since the IC will automatically limit power dissipation when the junction temperature reaches approximately 115°C.

### Board Layout Considerations

In order to deliver maximum charge current under all conditions, it is critical that the exposed metal pad on the backside of the LTC4069 package is soldered to the PC board copper and extending out to relatively large

copper areas or internal copper layers connected using vias. Correctly soldered to a 2500mm<sup>2</sup> double-sided 1 oz. copper board the LTC4069 has a thermal resistance of approximately 60°C/W. Failure to make thermal contact between the Exposed Pad on the backside of the package and the copper board will result in thermal resistances far greater than 60°C/W. As an example, a correctly soldered LTC4069 can deliver over 750mA to a battery from a 5V supply at room temperature. Without a backside thermal connection, this number could drop to less than 500mA.

### V<sub>CC</sub> Bypass Capacitor

Many types of capacitors can be used for input bypassing; however, caution must be exercised when using multi-layer ceramic capacitors. Because of the self-resonant and high Q characteristics of some types of ceramic capacitors, high voltage transients can be generated under some start-up conditions, such as connecting the charger input to a live power source. For more information, refer to Application Note 88.

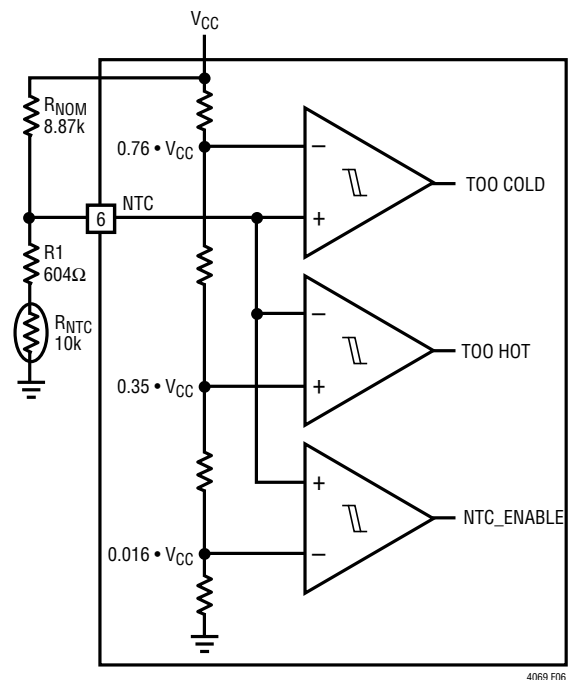

Figure 6. NTC Circuits

## APPLICATIONS INFORMATION

### Thermistors

The LTC4069 NTC trip points are designed to work with thermistors whose resistance-temperature characteristics follow Vishay Dale's "R-T Curve 1." The Vishay NTHS0603N01N1003J is an example of such a thermistor. However, Vishay Dale has many thermistor products that follow the "R-T Curve 1" characteristic in a variety of sizes. Furthermore, any thermistor whose ratio of  $R_{COLD}$  to  $R_{HOT}$  is about 6 will also work (Vishay Dale R-T Curve 1 shows a ratio of  $R_{COLD}$  to  $R_{HOT}$  of  $3.266/0.5325 = 6.13$ ).

Designers may want to use thermistors whose room temperature value is different than 100k. Vishay Dale has a number of values of thermistor from 32k to 100k that follow the "R-T Curve 1." Using different R-T curves, such as Vishay Dale "R-T Curve 2", is also possible. This curve, combined with LTC4069 internal thresholds, gives temperature trip points of approximately  $-3^{\circ}\text{C}$  (falling) and  $42^{\circ}\text{C}$  (rising), a delta of  $45^{\circ}\text{C}$ . This delta in temperature can be moved in either direction by changing the value of  $R_{NOM}$  with respect to  $R_{NTC}$ . Increasing  $R_{NOM}$  will move both trip points to higher temperatures. To calculate  $R_{NOM}$  for a shift to lower temperature for example, use the following equation:

$$R_{NOM} = \frac{R_{COLD}}{3.266} \cdot R_{NTC} \text{ at } 25^{\circ}\text{C}$$

where  $R_{COLD}$  is the resistance ratio of  $R_{NTC}$  at the desired cold temperature trip point. If you want to shift the trip points to higher temperatures use the following equation:

$$R_{NOM} = \frac{R_{HOT}}{0.5325} \cdot R_{NTC} \text{ at } 25^{\circ}\text{C}$$

where  $R_{HOT}$  is the resistance ratio of  $R_{NTC}$  at the desired hot temperature trip point.

Here is an example using a 10k R-T Curve 2 thermistor from Vishay Dale. The difference between the trip points is  $45^{\circ}\text{C}$ , from before, and we want the cold trip point to be  $0^{\circ}\text{C}$ , which would put the hot trip point at  $45^{\circ}\text{C}$ . The  $R_{NOM}$  needed is calculated as follows:

$$\begin{aligned} R_{NOM} &= \frac{R_{COLD}}{3.266} \cdot R_{NTC} \text{ at } 25^{\circ}\text{C} \\ &= \frac{2.816}{3.266} \cdot 10\text{k} = 8.62\text{k} \end{aligned}$$

The nearest 1% value for  $R_{NOM}$  is 8.66k. This is the value used to bias the NTC thermistor to get cold and hot trip points of approximately  $0^{\circ}\text{C}$  and  $45^{\circ}\text{C}$  respectively. To extend the delta between the cold and hot trip points, a resistor,  $R_1$ , can be added in series with  $R_{NTC}$  (see Figure 6). The values of the resistors are calculated as follows:

$$\begin{aligned} R_{NOM} &= \frac{R_{COLD} - R_{HOT}}{3.266 - 0.5325} \\ R_1 &= \left( \frac{0.5325}{3.266 - 0.5325} \right) \cdot (R_{COLD} - R_{HOT}) - R_{HOT} \end{aligned}$$

where  $R_{NOM}$  is the value of the bias resistor and  $R_{HOT}$  and  $R_{COLD}$  are the values of  $R_{NTC}$  at the desired temperature trip points. Continuing the example from before with a desired trip point of  $50^{\circ}\text{C}$ :

$$\begin{aligned} R_{NOM} &= \frac{R_{COLD} - R_{HOT}}{3.266 - 0.5325} = \frac{10\text{k} \cdot (2.816 - 0.4086)}{3.266 - 0.5325} \\ &= 8.8\text{k}, 8.87\text{k} \text{ is the nearest } 1\% \text{ value.} \\ R_1 &= 10\text{k} \cdot \left( \frac{0.5325}{3.266 - 0.5325} \right) \cdot (2.816 - 0.4086) - 0.4086 \\ &= 604\Omega, 604 \text{ is the nearest } 1\% \text{ value.} \end{aligned}$$

## APPLICATIONS INFORMATION

### NTC Trip Point Error

When a 1% resistor is used for  $R_{HOT}$ , the major error in the 40°C trip point is determined by the tolerance of the NTC thermistor. A typical 100k NTC thermistor has  $\pm 10\%$  tolerance. By looking up the temperature coefficient of the thermistor at 40°C, the tolerance error can be calculated in degrees centigrade. Consider the Vishay NTHS0603N-01N1003J thermistor, which has a temperature coefficient of  $-4\%/^{\circ}\text{C}$  at 40°C. Dividing the tolerance by the temperature coefficient,  $\pm 5\%/(4\%/^{\circ}\text{C}) = \pm 1.25^{\circ}\text{C}$ , gives the temperature error of the hot trip point.

The cold trip point error depends on the tolerance of the NTC thermistor and the degree to which the ratio of its value at 0°C and its value at 40°C varies from 6.14 to 1. Therefore, the cold trip point error can be calculated using the tolerance, TOL, the temperature coefficient

of the thermistor at 0°C, TC (in  $\%/^{\circ}\text{C}$ ), the value of the thermistor at 0°C,  $R_{COLD}$ , and the value of the thermistor at 40°C,  $R_{HOT}$ . The formula is:

$$\text{Temperature Error}(^{\circ}\text{C}) = \frac{\left( \frac{1 + \text{TOL}}{6.14} \cdot \frac{R_{COLD}}{R_{HOT}} - 1 \right) \cdot 100}{\text{TC}}$$

For example, the Vishay NTHS0603N01N1003J thermistor with a tolerance of  $\pm 5\%$ , TC of  $-5\%/^{\circ}\text{C}$  and  $R_{COLD}/R_{HOT}$  of 6.13, has a cold trip point error of:

$$\begin{aligned} \text{Temperature Error}(^{\circ}\text{C}) &= \frac{\left( \frac{1 + 0.05}{6.14} \cdot 6.13 - 1 \right) \cdot 100}{-5} \\ &= -0.95^{\circ}\text{C}, 1.05^{\circ}\text{C} \end{aligned}$$

## PACKAGE DESCRIPTION

**DC6 Package**  
**6-Lead Plastic DFN (2mm × 2mm)**  
 (Reference LTC DWG # 05-08-1703 Rev B)

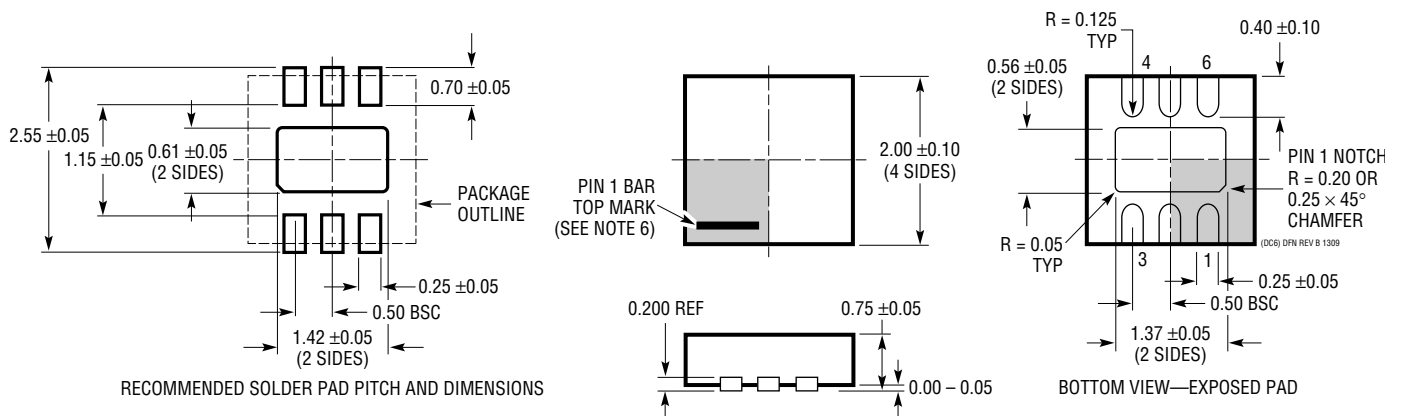

- NOTE:
1. DRAWING TO BE MADE A JEDEC PACKAGE OUTLINE M0-229 VARIATION OF (WCCD-2)
  2. DRAWING NOT TO SCALE
  3. ALL DIMENSIONS ARE IN MILLIMETERS

**REVISION HISTORY** (Revision history begins at Rev C)

REV	DATE	DESCRIPTION	PAGE NUMBER
C	10/13	Modified $V_{\text{FLOAT}}/V_{\text{BAT}}$ Regulated Output Voltage specs	2

## RELATED PARTS

PART NUMBER	DESCRIPTION	COMMENTS
<b>Battery Chargers</b>		
<a href="#">LTC1734</a>	Lithium-Ion Linear Battery Charger in ThinSOT™	Simple ThinSOT Charger, No Blocking Diode, No Sense Resistor Needed
<a href="#">LTC1734L</a>	Lithium-Ion Linear Battery Charger in ThinSOT	Low Current Version of LTC1734, $50\text{mA} \leq I_{\text{CHRG}} \leq 180\text{mA}$
<a href="#">LTC4002</a>	Switch Mode Lithium-Ion Battery Charger	Standalone, $4.7\text{V} \leq V_{\text{IN}} \leq 24\text{V}$ , 500kHz Frequency, 3 Hour Charge Termination
<a href="#">LTC4050</a>	Lithium-Ion Linear Battery Charger Controller	Features Preset Voltages, C/10 Charger Detection and Programmable Timer, Input Power Good Indication, Thermistor Interface
<a href="#">LTC4052</a>	Monolithic Lithium-Ion Battery Pulse Charger	No Blocking Diode or External Power FET Required, $\leq 1.5\text{A}$ Charge Current
<a href="#">LTC4053</a>	USB Compatible Monolithic Li-Ion Battery Charger	Standalone Charger with Programmable Timer, Up to 1.25A Charge Current
<a href="#">LTC4054</a>	Standalone Linear Li-Ion Battery Charger with Integrated Pass Transistor in ThinSOT	Thermal Regulation Prevents Overheating, C/10 Termination, C/10 Indicator, Up to 800mA Charge Current
<a href="#">LTC4057</a>	Lithium-Ion Linear Battery Charger	Up to 800mA Charge Current, Thermal Regulation, ThinSOT Package
<a href="#">LTC4058</a>	Standalone 950mA Lithium-Ion Charger in DFN	C/10 Charge Termination, Battery Kelvin Sensing, $\pm 7\%$ Charge Accuracy
<a href="#">LTC4059/LTC4059A</a>	900mA Linear Lithium-Ion Battery Charger	2mm $\times$ 2mm DFN Package, Thermal Regulation, Charge Current Monitor Output, Version A has $\overline{\text{ACPR}}$ Function
<a href="#">LTC4061</a>	Standalone Li-Ion Charger with Thermistor Interface	4.2V, $\pm 0.35\%$ Float Voltage, Up to 1A Charge Current, 3mm $\times$ 3mm DFN
<a href="#">LTC4061-4.4</a>	Standalone Li-Ion Charger with Thermistor Interface	4.4V (Max), $\pm 0.4\%$ Float Voltage, Up to 1A Charge Current, 3mm $\times$ 3mm DFN
<a href="#">LTC4062</a>	Standalone Linear Li-Ion Battery Charger with Micropower Comparator	4.2V, $\pm 0.35\%$ Float Voltage, Up to 1A Charge Current, 3mm $\times$ 3mm DFN
<a href="#">LTC4063</a>	Li-Ion Charger with Linear Regulator	Up to 1A Charge Current, 100mA, 125mV LDO, 3mm $\times$ 3mm DFN
<a href="#">LTC4065/LTC4065A</a>	Standalone Li-Ion Battery Charger	4.2V, $\pm 0.6\%$ Float Voltage, Up to 750mA Charge Current, 2mm $\times$ 2mm DFN, Version A has $\overline{\text{ACPR}}$ Function
<a href="#">LTC4411/LTC4412</a>	Low Loss PowerPath™ Controller in ThinSOT	Automatic Switching Between DC Sources, Load Sharing, Replaces ORing Diodes
<b>Power Management</b>		
<a href="#">LTC3405/LTC3405A</a>	300mA ( $I_{\text{OUT}}$ ), 1.5MHz, Synchronous Step-Down DC/DC Converter	95% Efficiency, $V_{\text{IN}}$ : 2.7V to 6V, $V_{\text{OUT}} = 0.8\text{V}$ , $I_{\text{Q}} = 20\mu\text{A}$ , $I_{\text{SD}} < 1\mu\text{A}$ , ThinSOT Package
<a href="#">LTC3406/LTC3406A</a>	600mA ( $I_{\text{OUT}}$ ), 1.5MHz, Synchronous Step-Down DC/DC Converter	95% Efficiency, $V_{\text{IN}}$ : 2.5V to 5.5V, $V_{\text{OUT}} = 0.6\text{V}$ , $I_{\text{Q}} = 20\mu\text{A}$ , $I_{\text{SD}} < 1\mu\text{A}$ , ThinSOT Package
<a href="#">LTC3411</a>	1.25A ( $I_{\text{OUT}}$ ), 4MHz, Synchronous Step-Down DC/DC Converter	95% Efficiency, $V_{\text{IN}}$ : 2.5V to 5.5V, $V_{\text{OUT}} = 0.8\text{V}$ , $I_{\text{Q}} = 60\mu\text{A}$ , $I_{\text{SD}} < 1\mu\text{A}$ , MS Package
<a href="#">LTC3440</a>	600mA ( $I_{\text{OUT}}$ ), 2MHz, Synchronous Buck-Boost DC/DC Converter	95% Efficiency, $V_{\text{IN}}$ : 2.5V to 5.5V, $V_{\text{OUT}} = 2.5\text{V}$ , $I_{\text{Q}} = 25\mu\text{A}$ , $I_{\text{SD}} < 1\mu\text{A}$ , MS Package
<a href="#">LTC4413</a>	Dual Ideal Diode in DFN	2-Channel Ideal Diode ORing, Low Forward ON Resistance, Low Regulated Forward Voltage, $2.5\text{V} \leq V_{\text{IN}} \leq 5.5\text{V}$

ThinSOT is a trademark of Linear Technology Corporation.